

Ultra-High Vacuum Turbo Molecular Pump UTM-50

Internal structure

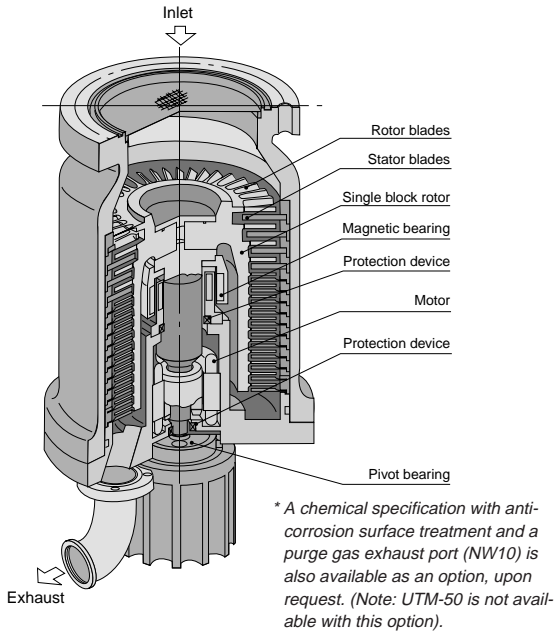

Features

- Long lifetime and reduction of bearing maintenance**
 A non-contact permanent magnetic bearing is used for the upper bearing and a pivot bearing using fluorine oil is used in the lower bearing. Mechanical contact during high-speed rotation is thereby completely eliminated. Bearing and oil replacements are therefore unnecessary and a long, lifetime is typically the case with these pumps.
- High pumping performance for hydrogen and helium**
 A high precision dynamically balanced rotor built with independent fin line design and high performance bearings make high rotational speeds possible. This design results in high compression ratios for low molecular weight gases such as hydrogen and helium.
- Clean, hydrocarbon-free vacuum**
 Through the use of a pivot bearing and chemically stable fluorine oil, with its low saturation vapor pressure, an oil-free environment very close to that of magnetic levitation models is realized. This makes an extremely clean, ultra-high vacuum possible (saturation vapor pressure is on the order of 10^{-11} Pa at 20 °C).
- Low noise and vibration**
 Noise and vibration are reduced with the use of a high precision dynamically balanced rotor and high performance bearings.

UTM-50



N₂/H₂ Pumping Speed

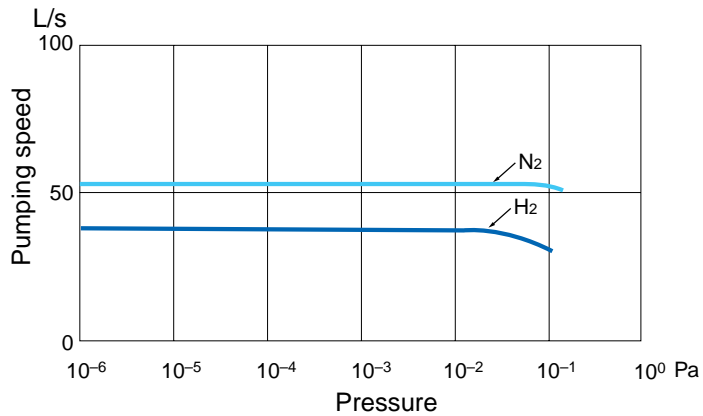

External Dimension Diagram

(unit: mm)

• Main unit

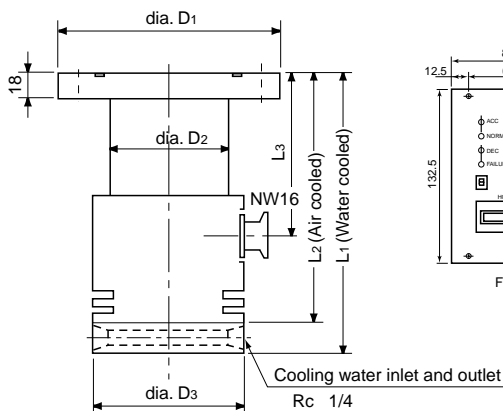

• Power supply

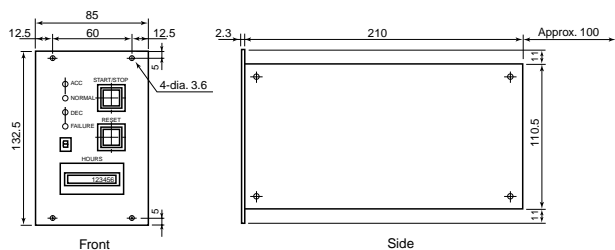

unit: mm

Inlet port	dia. D ₁	dia. D ₂	dia. D ₃	L ₁	L ₂	L ₃
JIS VG65	145	79	100	186	166	110
CF114	114	76	100	186	166	110