

Precise Microplate Paddle Mixer [MICROPADDLE IMP-096A]

Precise microplate paddle mixer "MICROPADDLE" enables direct mixing for 96 well microplate, features high precision and accuracy, wide rotation speed setting and independent rotation control for each column, promise your laboratory works more comfortable and efficiency.

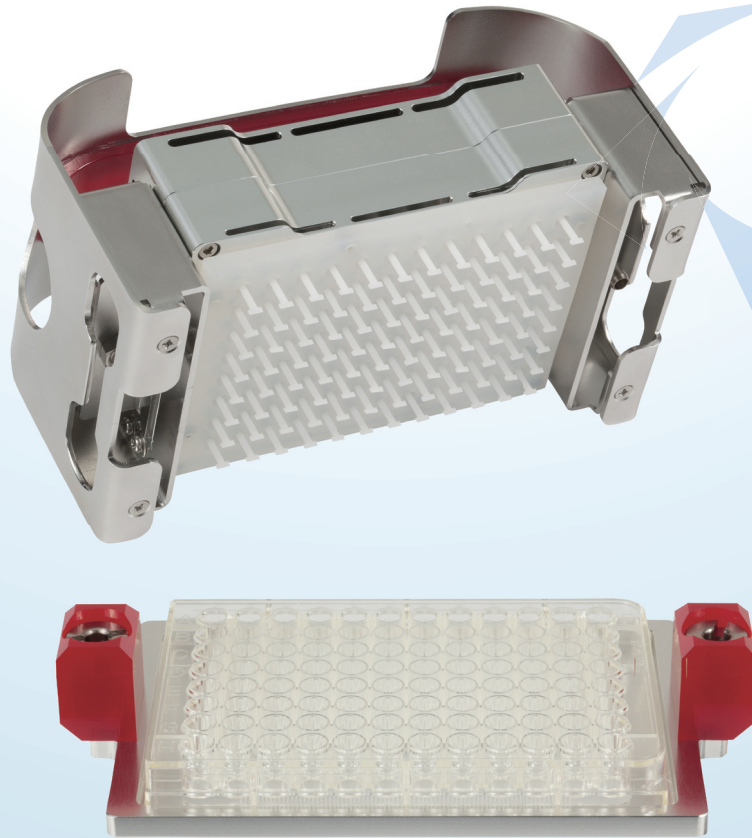

Features

- ▶ **Low volume mixing**
Reduce sample consumption by mixing with 96 well microplate
- ▶ **Highly accuracy and precision mixing**
Rotation speed from 1 to 3000 min^{-1} (1 min^{-1} increment) with $\pm 1\%$ precision.
- ▶ **Low rotation speed mixing**
Available highly precise gentle mixing below 300 min^{-1}
- ▶ **High efficiency mixing**
Direct paddle mixing and high rotation speed enable high efficiency mixing.
- ▶ **Multiple rotation speed setting simultaneously**
12 Independent rotation speed setting in 1 microplate facilitates your optimum rotation setting search.

Applications

- ▶ Microplate dissolution testing
- ▶ Cell base assay, ELISA
- ▶ Emulsifying
- ▶ Parallel Artificial Membrane Permeation Assay

initium

ULVAC  SOLUTIONS

Precise Microplate Paddle Mixer [MICROPADDLE IMP-096A]

Specifications

Model	MICROPADDLE IMP-096A
Mixing method	Paddle rotation
Number of paddle	96
Corresponding plate	96 well microplate
Driving method	Stepping motor
Rotation speed control	Independent control for each column
Rotation speed range	0 ~ 3000 min ⁻¹
Rotation speed setting	1 min ⁻¹ increment
Rotation speed accuracy	± 1% or ±1 min ⁻¹ whichever is higher
Environmental operation temperature	10 ~ 40 °C
Environmental operation humidity	Below 85% relative humidity
Control method	MICROPADDLE software (CD)
Unit multiply	Maximum 12 units controllable by 1 PC
Power	90 ~ 264 VAC, 47 ~ 63 Hz, 2A Attached plug supports maximum 125 VAC system
Weight	1.5 kg *Mixing unit only

Instrument configuration

Mixing unit	1
Control unit	1
Mixing paddle	96
Plate base	1
Standard cable	1
AC adapter	1
Wash plate	1
Silicone rubber sheet A05	1
USB serial converter	1
RS232C cable	1
MICROPADDLE Software (CD)	1
Instruction Manual	1

Main options

Control PC for MICROPADDLE
Silicone rubber sheet (A01 ~ 07)
USB Hub
Inspection certificate

Dimensions

Unit:mm

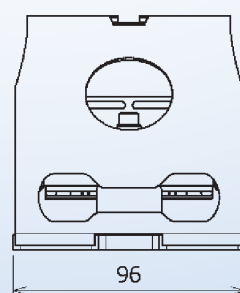
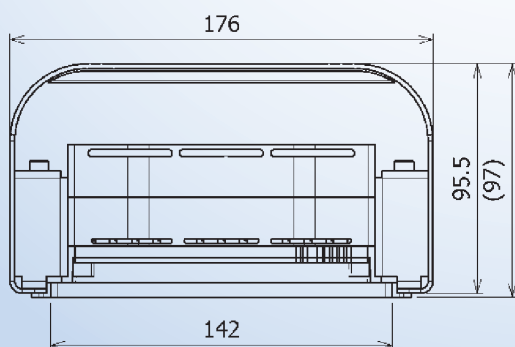
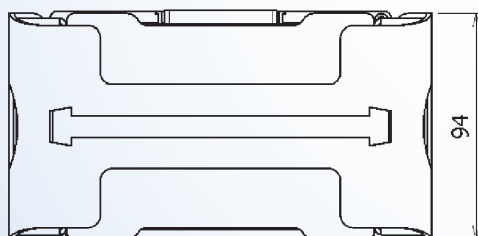

Rotation speed dependence of the mixing

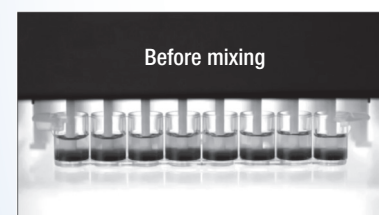

5 sec. mixing

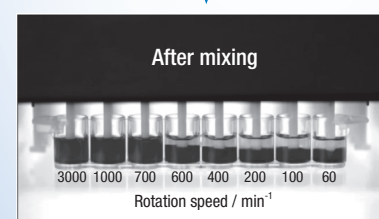

* Using a dye solution of high viscosity

ULVAC, Inc. Components Division

www.ulvac.co.jp/en

Overseas Sales in Japan TEL +81-467-89-2261

USA : ULVAC Technologies, Inc. TEL +1-978-686-7550
 GERMANY : ULVAC GmbH TEL +49-89-960909-0
 CHINA : ULVAC (SHANGHAI) Trading Co.,Ltd. TEL +86-21-6127-6618
 TAIWAN : ULVAC TAIWAN, Inc. TEL +886-3-579-5688
 KOREA : ULVAC KOREA, Ltd. TEL +82-31-683-2922
 SINGAPORE : ULVAC SINGAPORE PTE LTD TEL +65-6542-2700

PHILIPPINES : ULVAC SINGAPORE PTE LTD Philippines Branch TEL +63-46-437-7700
 VIETNAM : ULVAC SINGAPORE PTE LTD Vietnam Representative Office TEL +84-8-6299-8262
 INDONESIA : ULVAC SINGAPORE PTE LTD Indonesia Representative Office TEL +62-21-8990-5070
 THAILAND : ULVAC (THAILAND) LTD TEL +66-2-7388883
 MALAYSIA : ULVAC MALAYSIA SDN. BHD. TEL +60-3-5121-4700
 INDIA : ULVAC, Inc., India Branch TEL +91-40-27007006

▶ This catalog is subject to change without notice.
 ▶ This catalog is published in order to sell this product in overseas. Please see Japanese catalog when purchasing in Japan.